

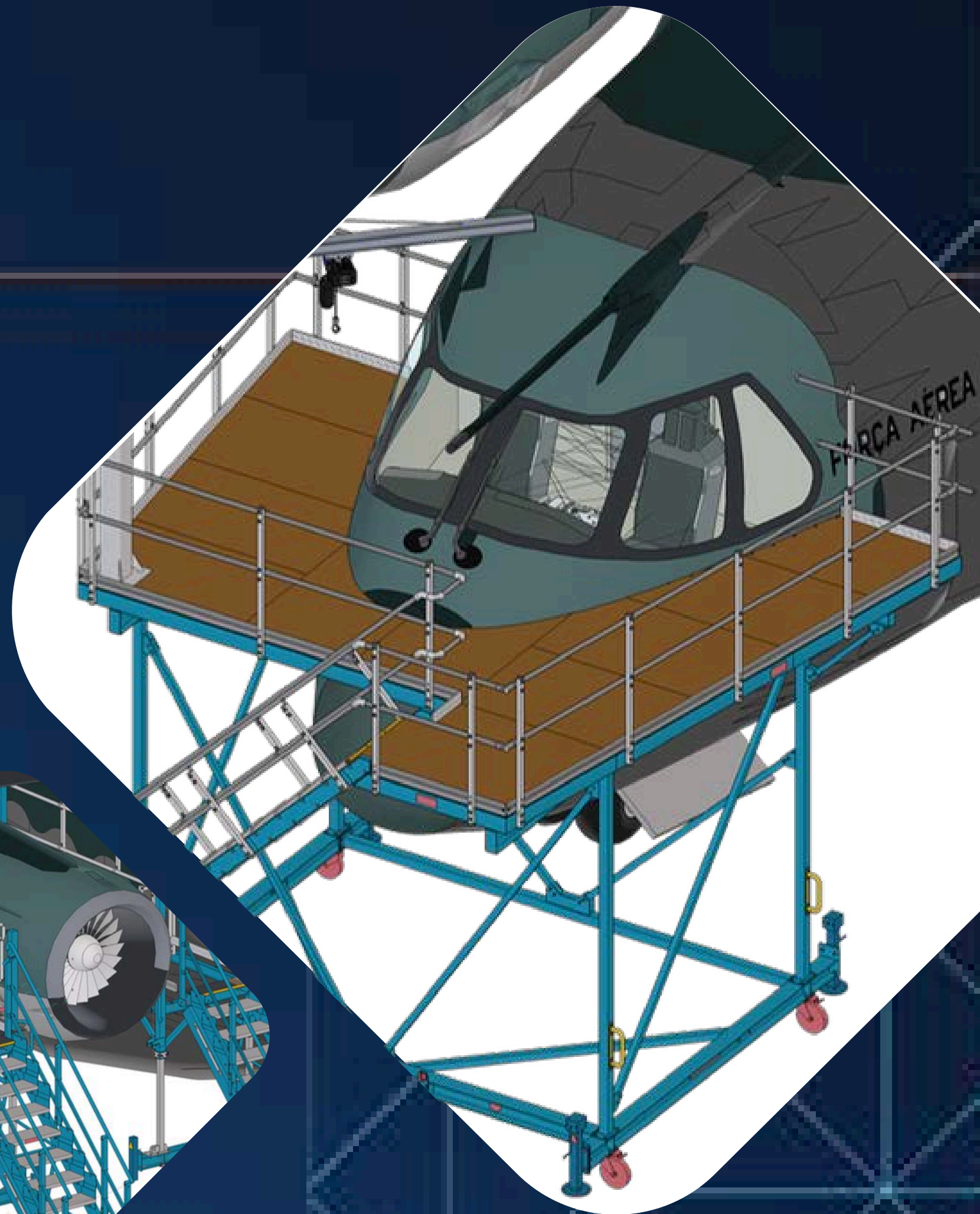

nijl®

KC390 Access Equipment

www.nijlgroup.com

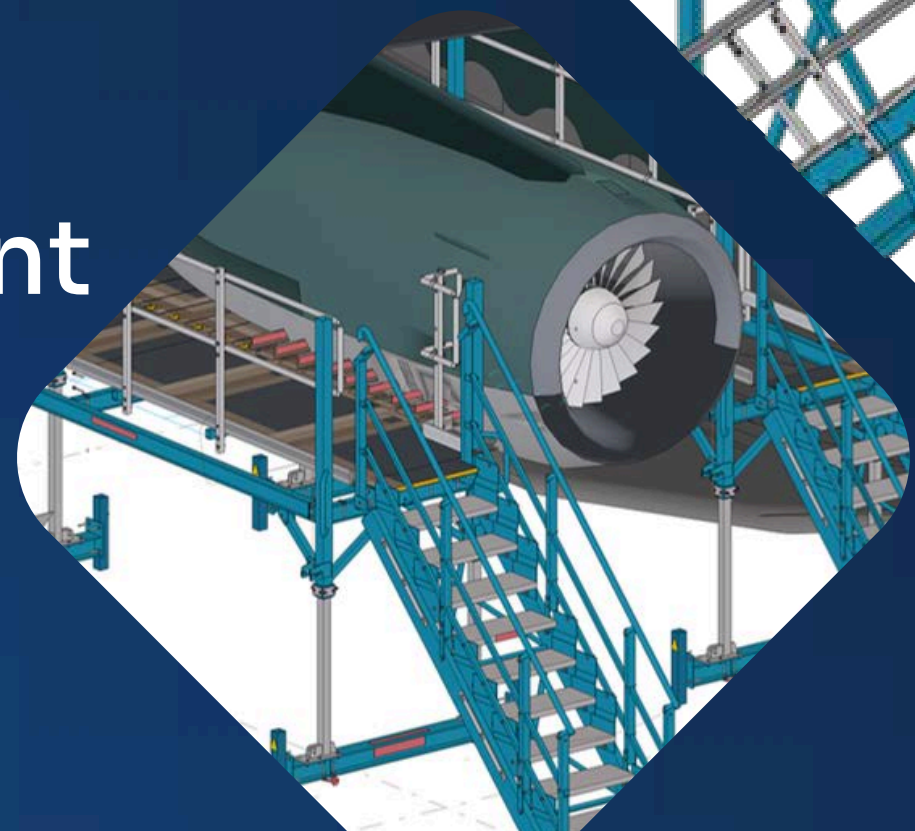

— KC390 Access Solutions

Efficient and safe maintenance access is essential to keeping the KC-390 aircraft mission-ready. Our KC-390 aircraft access solutions are specifically engineered to support maintenance crews with reliable, ergonomic, and compliant access to all critical service areas. Designed with safety, flexibility, and operational efficiency in mind, our systems minimize downtime while ensuring full compliance with international standards—delivering dependable support throughout every phase of maintenance and inspection.

- ENGINE ACCESS SOLUTIONS

- OVERWING AND REAR (POD) FUEL TANK ACCESS

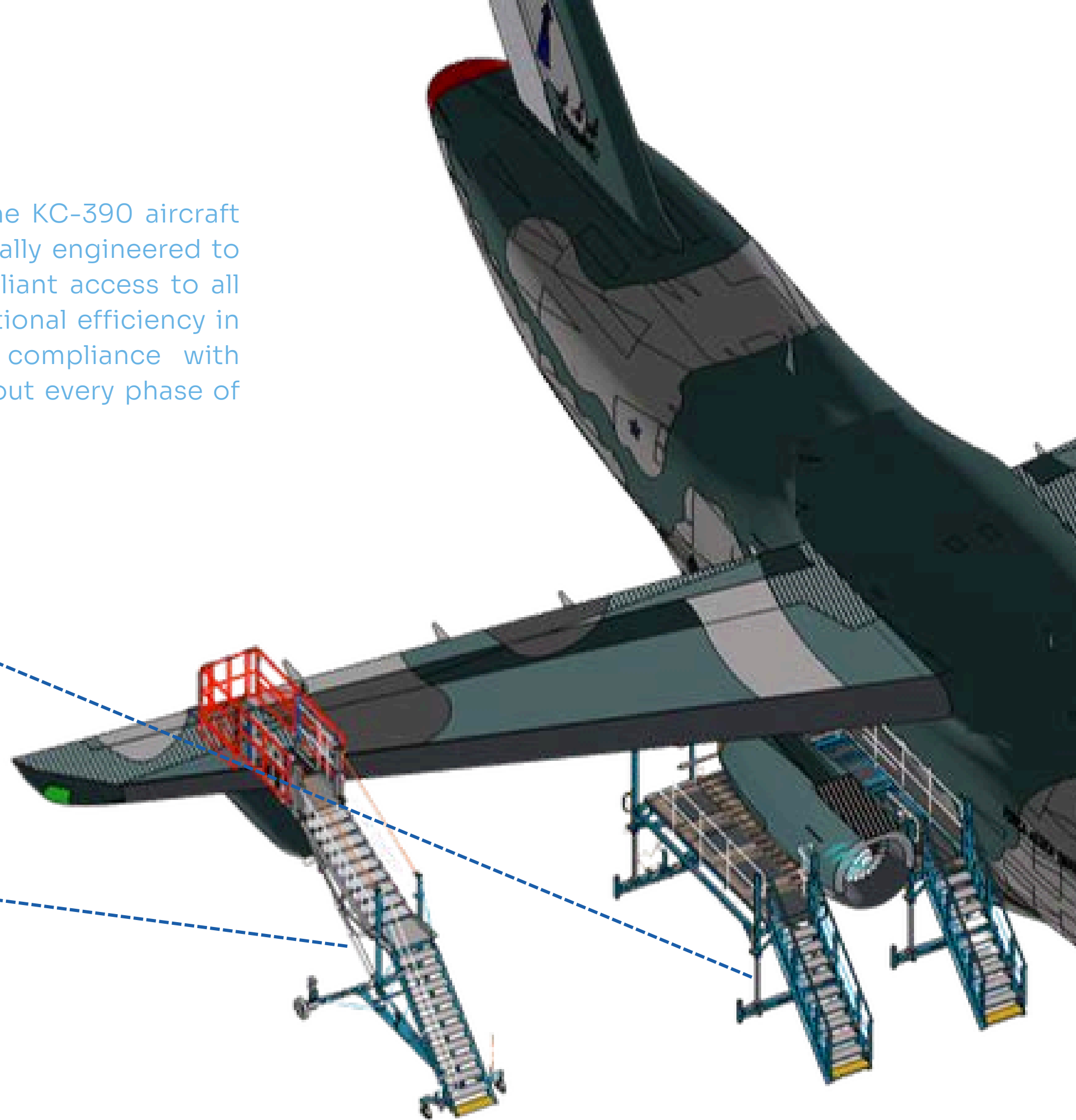

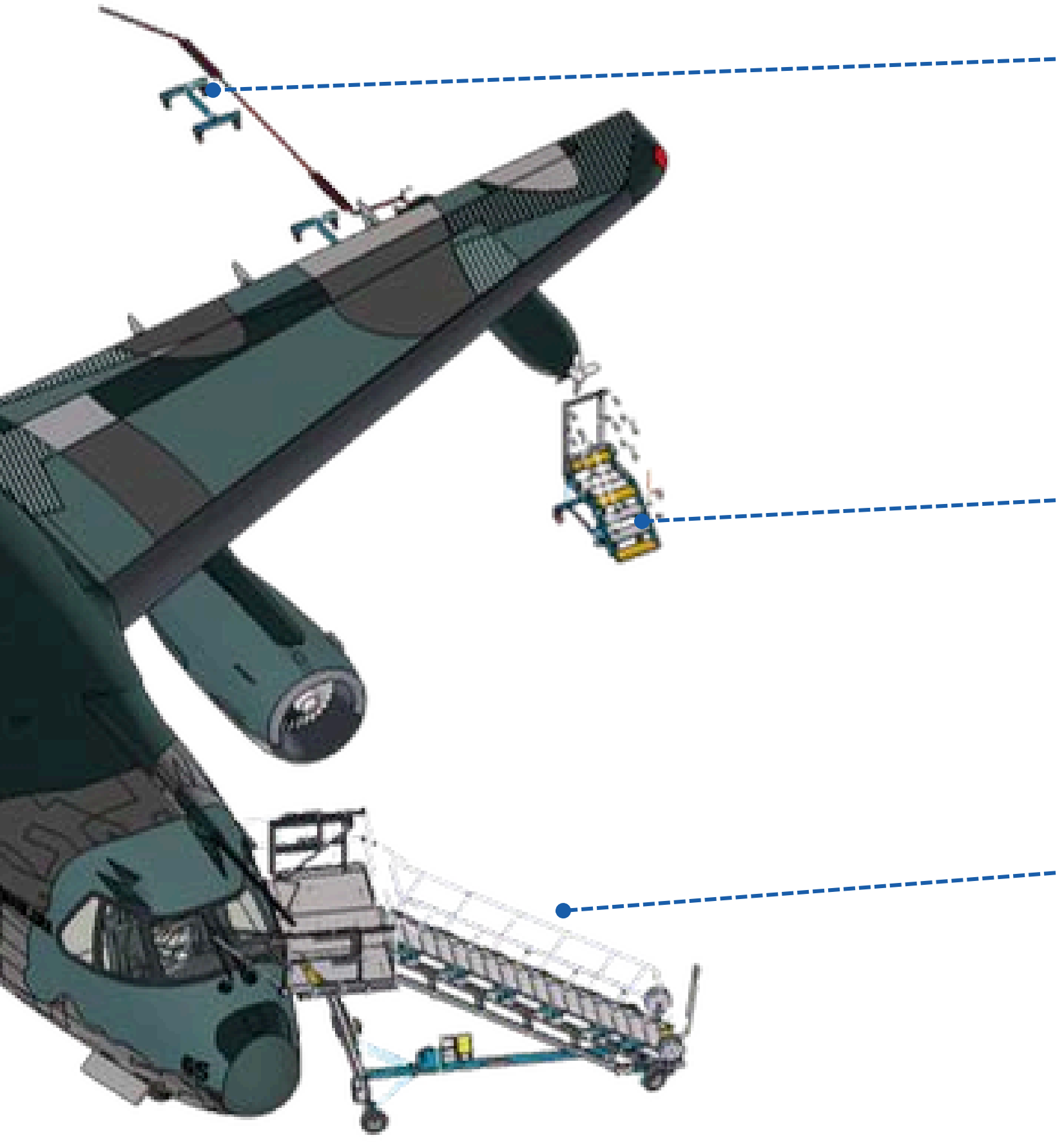

- HOSE INSPECTION DOLLY

- UNDERWING ACCESS

- COCKPIT WINDOW AND NOSE ACCESS

NOSE DOCK

Nose dock is engineered for efficient maintenance of the KC390 aircraft ground mobility ensures flexible positioning within the hangar. The dock provides full access to the nose section, including the skin surface, probes, cockpit windows, and crown.

Adjustable flooring and railing systems enhance docking ease and safety. Constructed from a durable mix of aluminum and steel, the dock meets the latest safety standards and supports optimized workflow for multiple mechanics, tools, and equipment.

KEY FEATURES:

- Adjustable railing following the aircraft contours for access and fall protection
- Rubber padding for aircraft surface protection
- JIB Crane of installation and removal of cockpit windows

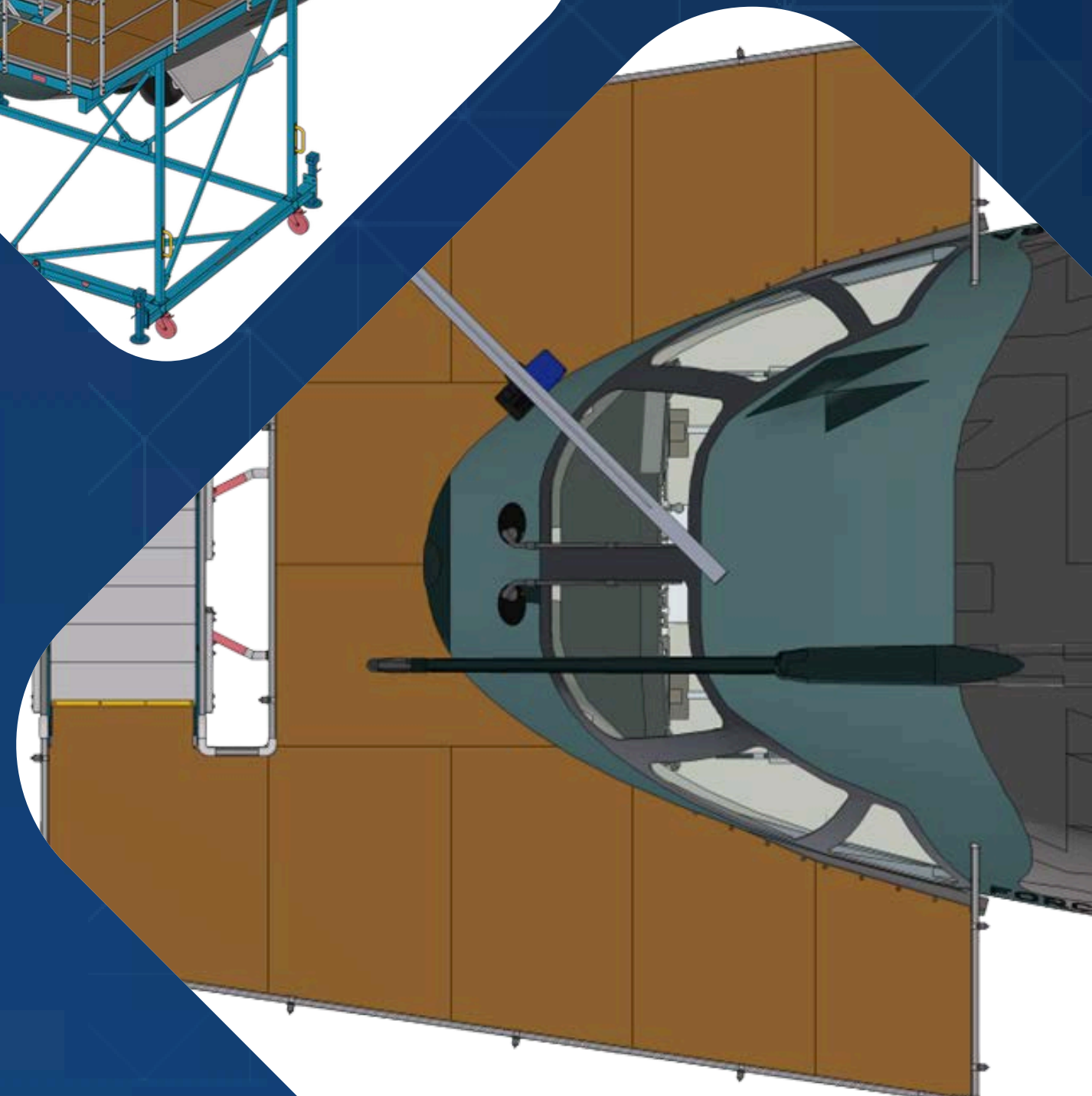
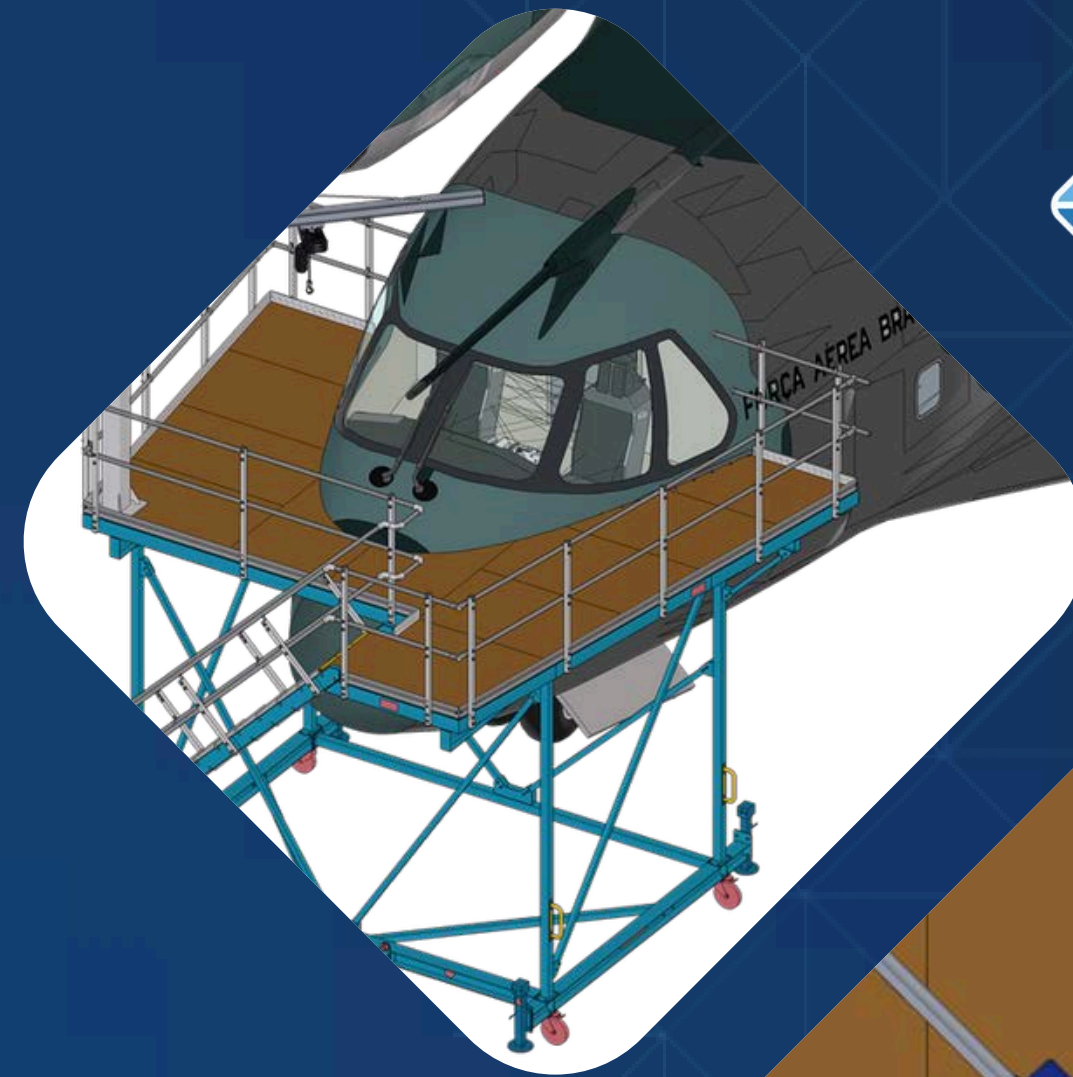

COCKPIT WINDOW ACCESS

SFS19T800-HS (PAXCWD)

Cockpit window access requires high precision and stability, especially on large military transports and fighter aircraft with sensitive avionics and structural components. Our dock systems are engineered to provide controlled, close-proximity access to the cockpit window area, ensuring safe and accurate maintenance or inspection. Designed to align precisely with the aircraft nose geometry, the modular system maintains clearances to protect glazing and surrounding structures while offering repeatable positioning and adaptability across different aircraft variants.

KEY FEATURES:

- Foam-lined rails and non-marking bumpers
- Compatible with open or closed canopies
- Designed for helmeted crew boarding (pilot steps)
- FOD-conscious materials and tool storage options

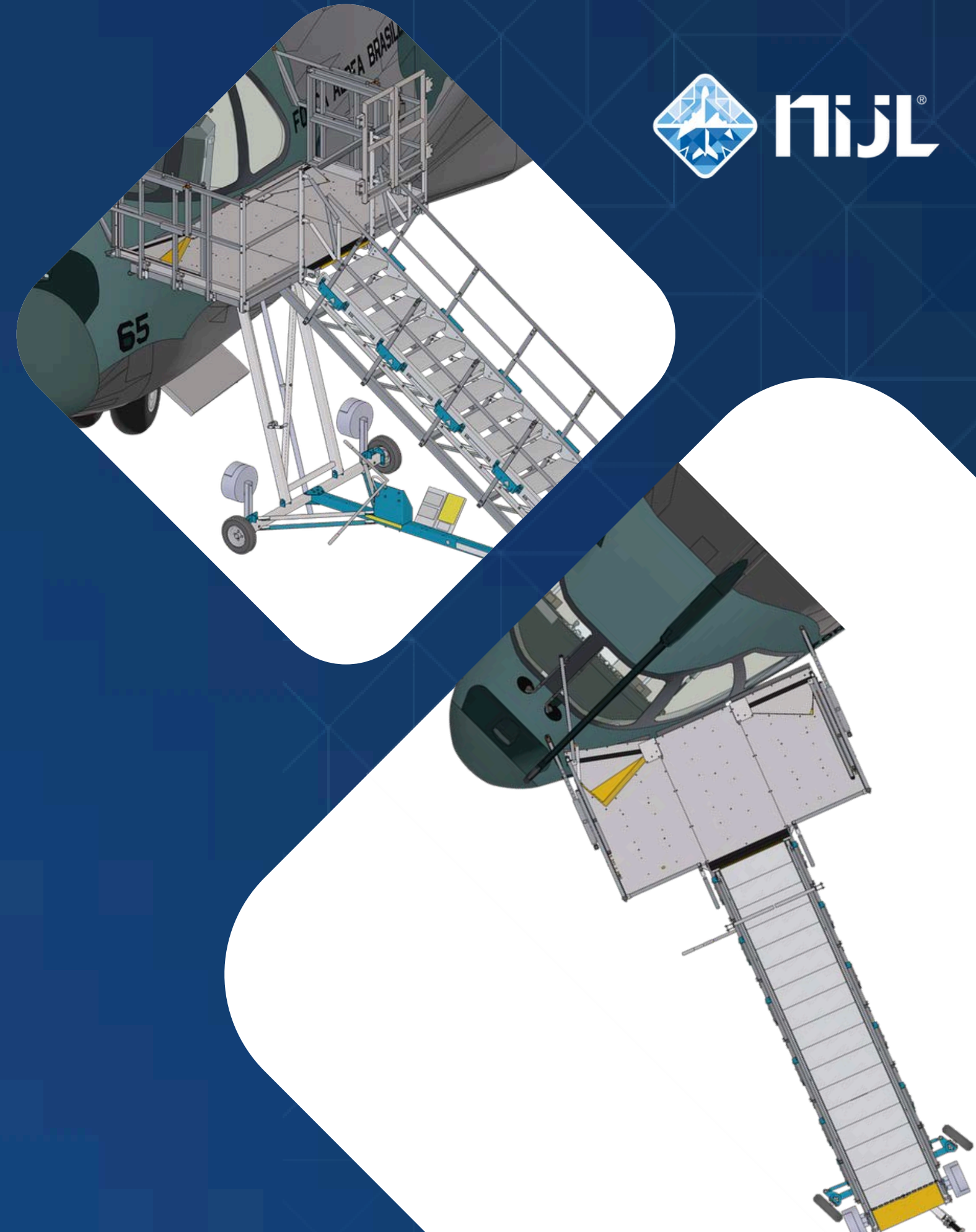

OVERWING (FUEL TANK) ACCESS

MPS12T22T800

The MPS stairs feature a robust and stable construction while remaining lightweight through an optimal combination of steel and aluminium, making them easy to handle and reposition. In addition, the MPS can be equipped with a platform enclosure kit, specifically developed to provide safe and efficient access to overwing, pylons, masts, and similar structures. This kit integrates seamlessly with the stair system, offering secure attachment, optimized reach, and enhanced safety for operators working at height. With a modular design, the MPS system can be fully configured to meet specific customer needs and site requirements.

KEY FEATURES:

- Design according to NEN-EN-ISO-14122
- Mounted to basic fixed railing system with steel structural elements
- All gates in colour orange RAL2004
- Locking systems included on gates
- Black non-staining rubber padding
- Slidable side railing with front gates included to enclose FWD working area to safely access tank inspection hatches
- Vertical movable gates include to minimize gap between gate and wing surface

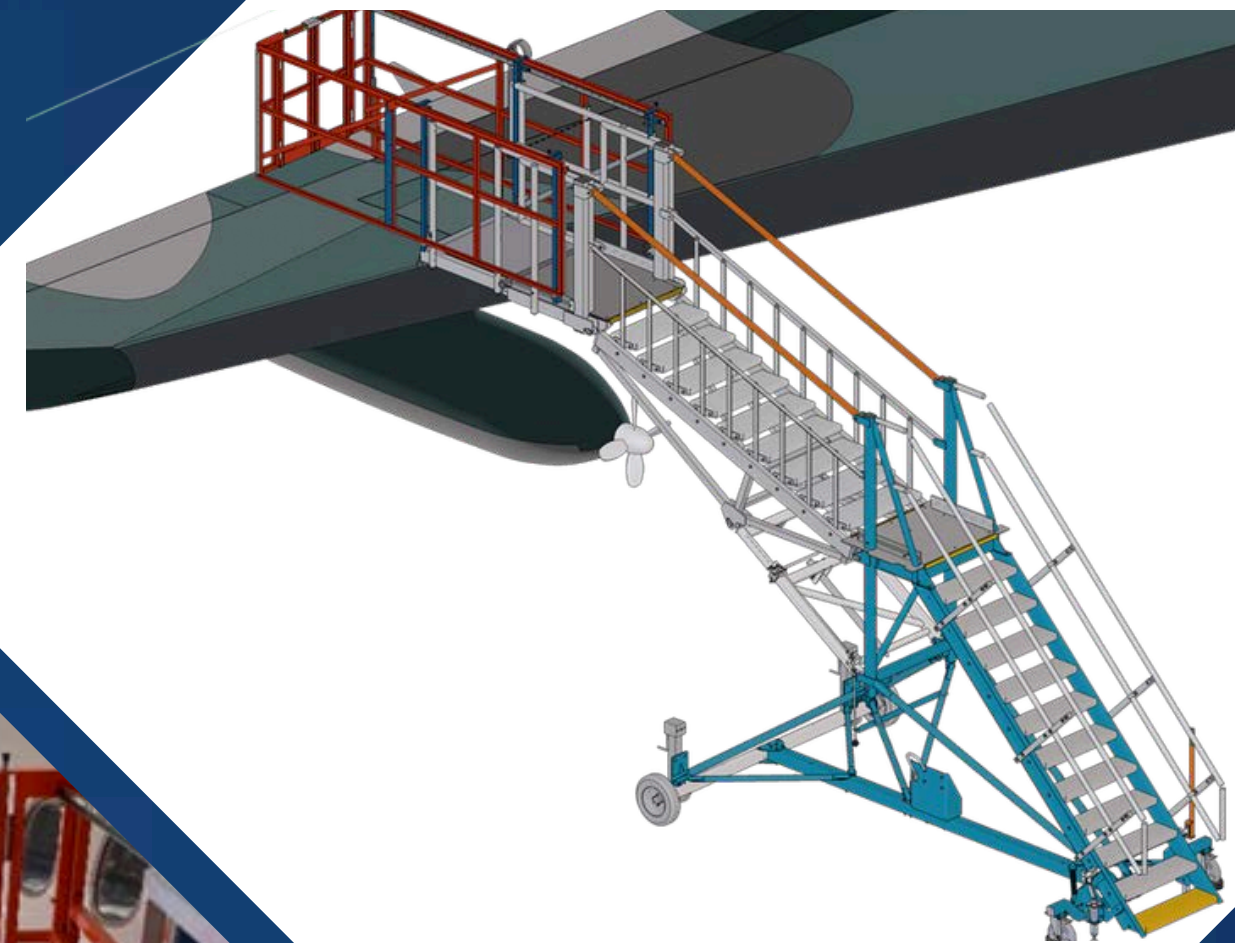

REAR FUEL TANK (POD) ACCESS

FIX04T700-LS

Safe and efficient access to the rear fuel tank POD is critical for streamlined maintenance operations. Our dedicated rear fuel tank POD access solution is engineered to provide secure and reliable access, combining a robust and stable design with excellent manoeuvrability in confined maintenance environments. Available in different heights and built with a modular concept, the system can be easily configured to meet specific customer and aircraft requirements, ensuring flexibility, safety, and efficiency during inspection and servicing tasks.

KEY FEATURES:

- Design according to NEN-EN-ISO-14122
- Quick jacking device with single lever
- Lightweight because of optimal mix of steel and aluminium
- Fixed hoop up step incorporated into top platform
- Black non-staining rubber protection

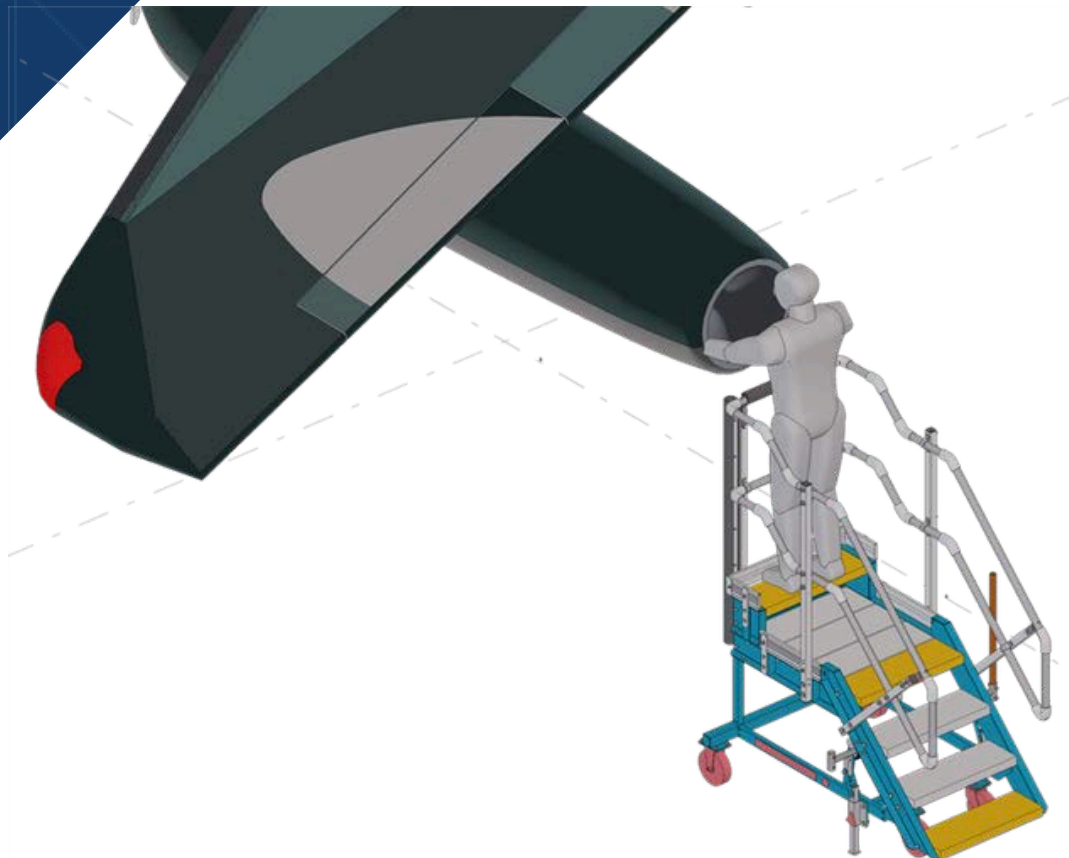

HOSE INSPECTION DOLLY

Designed specifically for maintenance and inspection tasks, our hose inspection dolly offers a reliable and practical solution for handling aircraft hoses. It features a robust and stable construction with a welded steel base frame that ensures durability and long-term performance. The dolly is easy to manoeuvre and available in different heights, supporting ergonomic working conditions across a variety of inspection activities. Its fully rubber-protected top structure accommodates multiple hose sizes, enabling controlled and secure inspections, while black non-staining rubber protection prevents damage to hoses and surrounding surfaces. Optional additional storage and signage can be added, making the dolly a versatile and well-organized addition to any maintenance environment.



ENGINE ACCESS

FRS10T800-HS

Our Fixed Height Stairs (FRSIII), designed in accordance with NEN-EN-ISO-14122, feature a unique and flexible railing system (FRS) that enables fast and safe access in areas with limited space. The stairs are equipped with a quick jacking device operated by a single lever, ensuring ease of use and efficient positioning. Their robust and stable construction is combined with a lightweight design, achieved through an optimal mix of steel and aluminium, making the system easy to manoeuvre. Available in different heights, the FRSIII has a modular design that can be configured to meet specific customer requirements.

KEY FEATURES:

- Black non-staining rubber protection
- Non-skid aluminium flooring
- Aluminium handrail and guardrail
- Non-skid aluminium steps
- Quick jacking device with single lever
- Labels and signage
- Polyurethane castor wheels
- Flexible railing system (FRS III®)



— ADJUSTABLE UNDERCOWL ENGINE ACCESS

The engine access stands (LH & RH) are designed to provide maintenance and overhaul personnel with a stable and controlled working environment for engine-related tasks. Engineered to conform precisely to the local engine geometry, the stands enable close positioning to the nacelle and structure, ensuring effective access to the under fan cowling area. This geometry-driven design supports accurate alignment with the engine, allowing maintenance activities to be performed efficiently while maintaining consistent safety and structural stability.

KEY FEATURES:

- Incremental height adjustment platform
- Design according to NEN-EN-ISO-14122
- CE certified
- Robust and stable design
- Optimal mix of steel and aluminium
- Extendable modular platform to contour to engine geometry
- Automatically adjustable staircase fixed to platform ensure safe access
- Flexible railing system

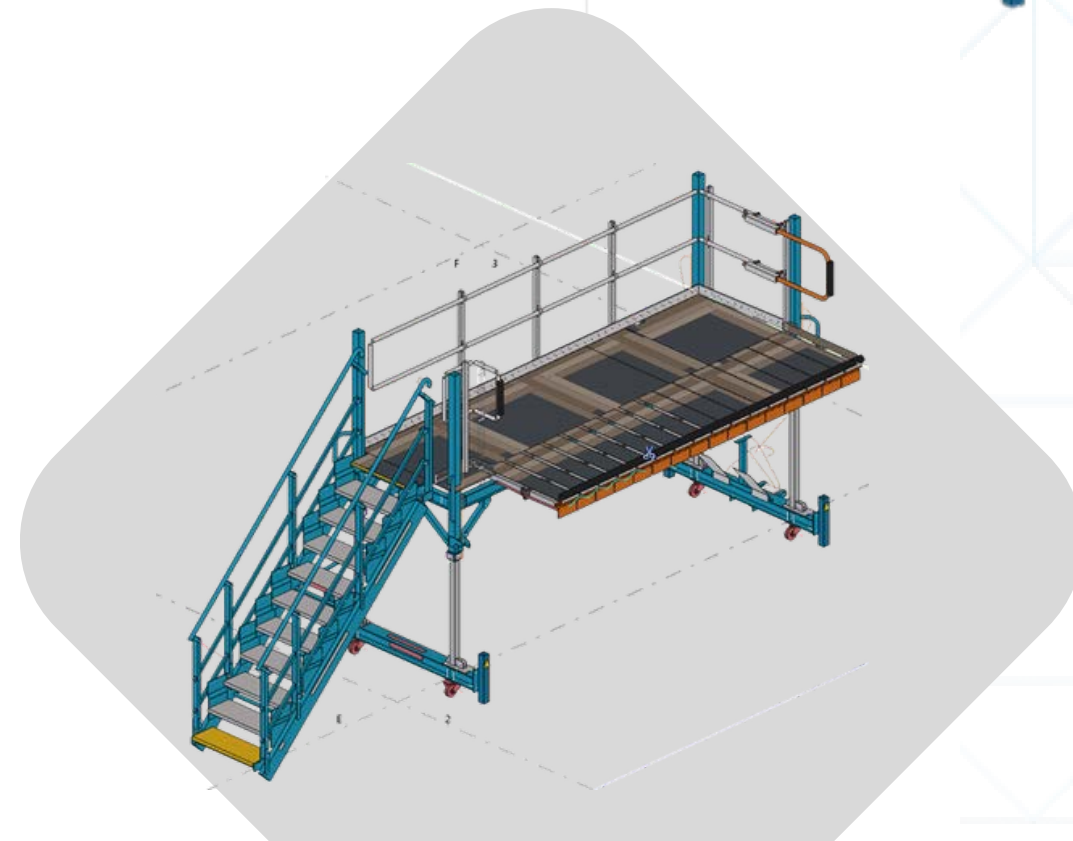
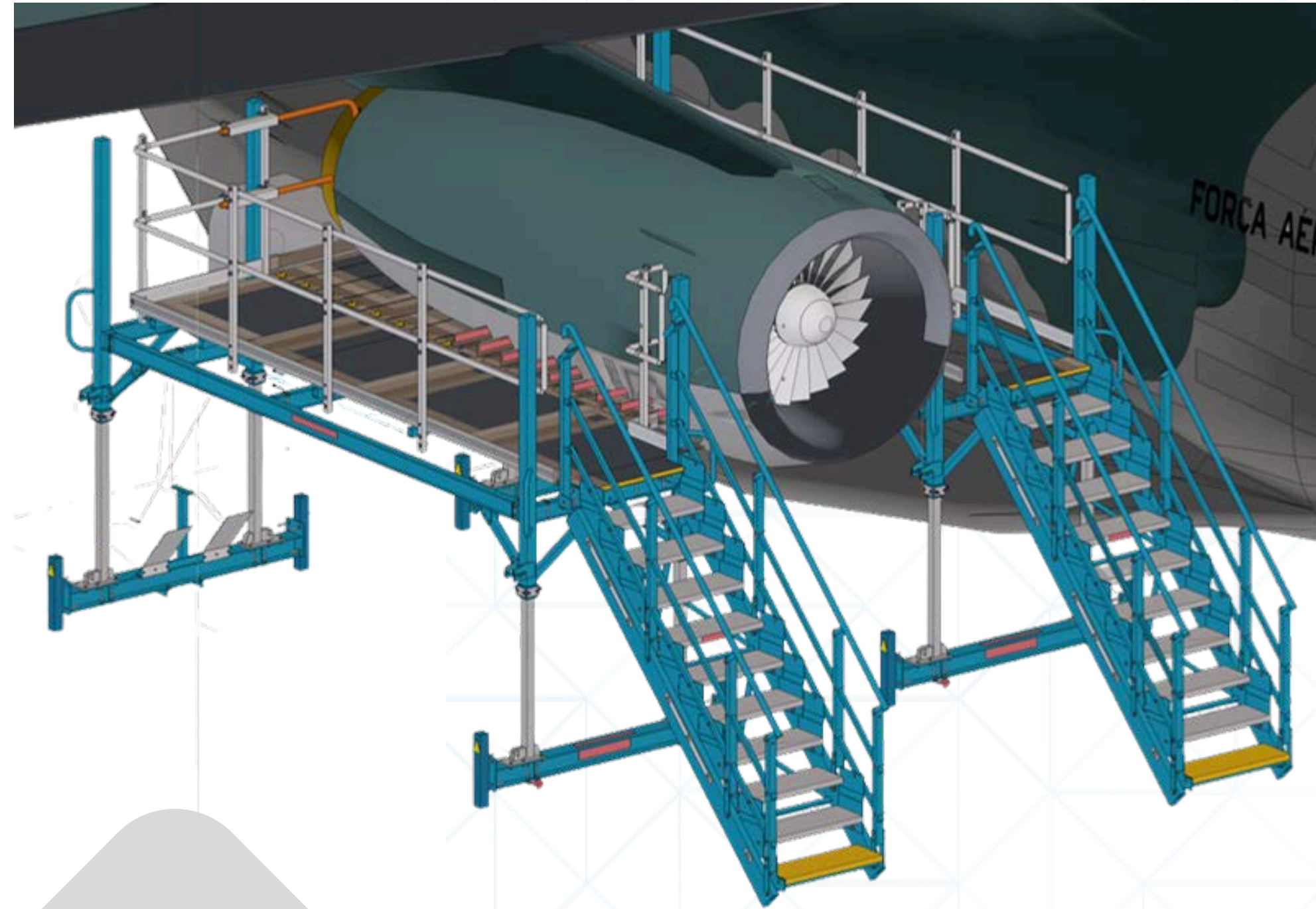

— FIXED UNDERCOWL ENGINE ACCESS

KEY FEATURES:

- Provides under fan cowl access with opened fan cowlings
- Time-efficient positioning procedure
- Single module fixed height dock configured for optimal ergonomics and ease of maintenance operation
- Retractable platform railing for safety and ease of positioning
- Foldable railing for fall protection towards engine inlet cowl
- Large work platform for mechanic and toolbox

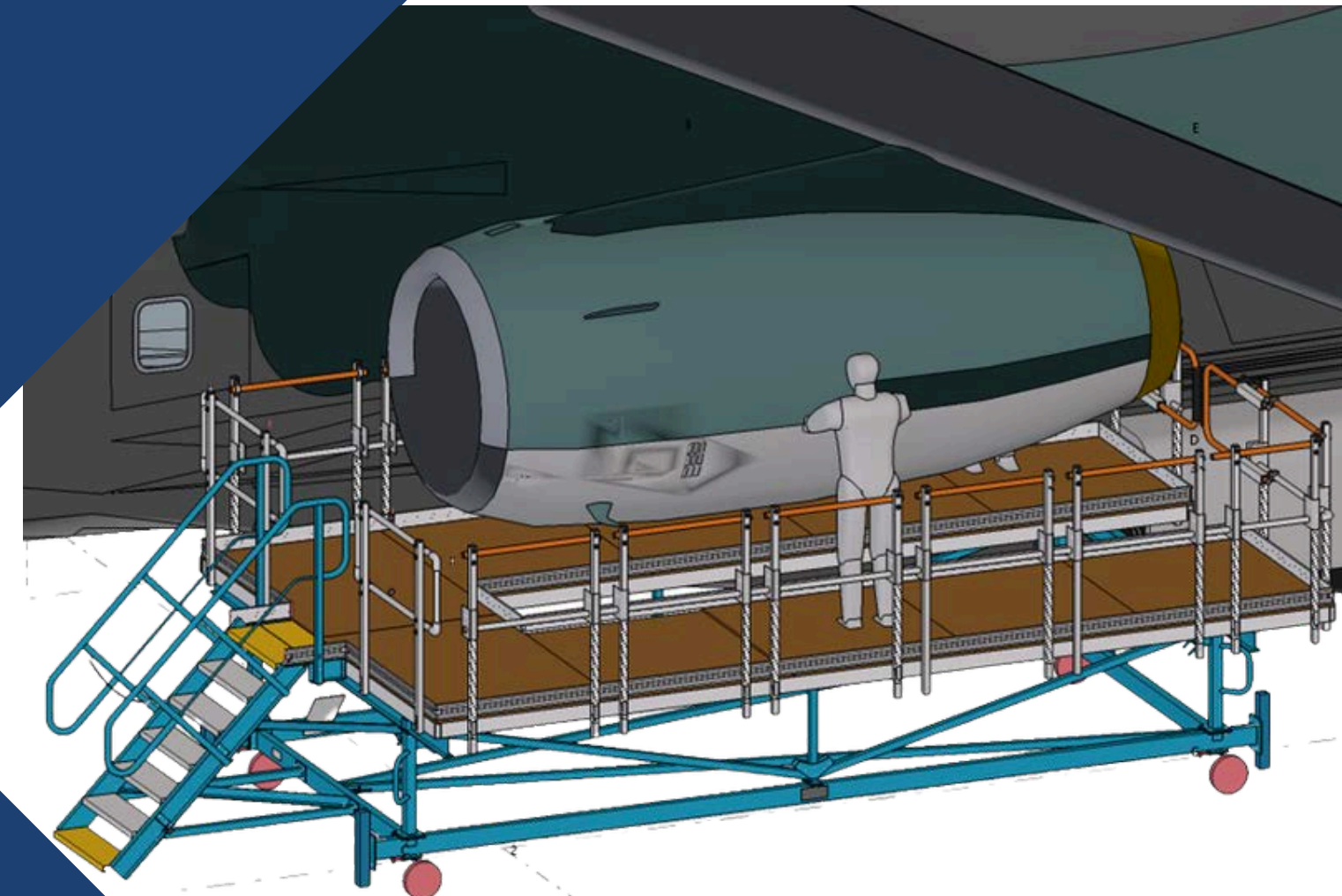
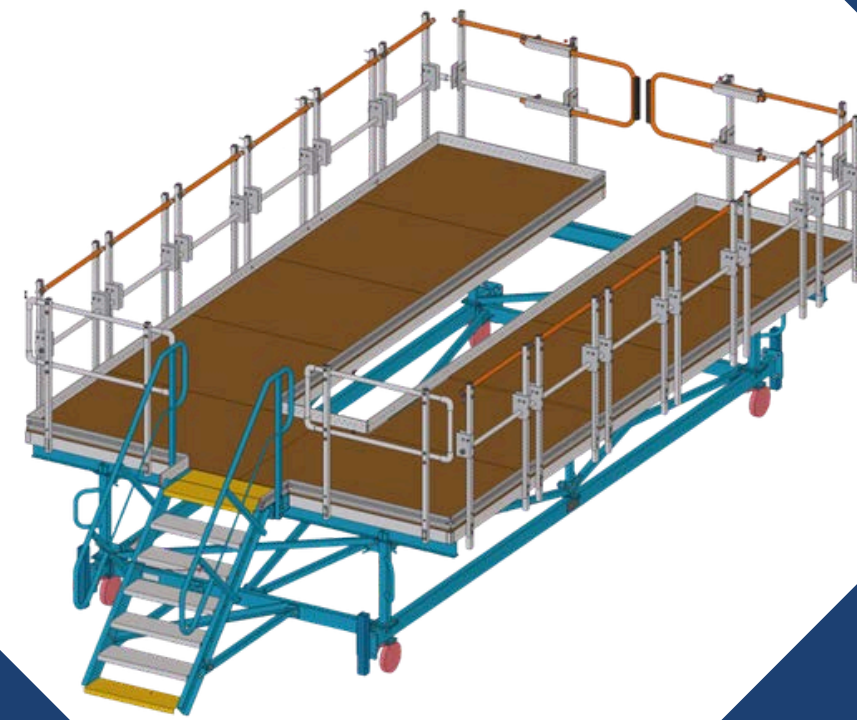

ENGINE PYLON ACCESS

MPS12T22T800 (+ Pylon kit)

Our Height Adjustable Stairs (MPS) are designed in accordance with NEN-EN-ISO-14122 and are CE certified, ensuring compliance with the highest safety standards. They are ideal for areas that require a high degree of height flexibility, thanks to their precise incremental height adjustment. The MPS stairs feature a robust and stable construction while remaining lightweight through an optimal combination of steel and aluminium, making them easy to handle and reposition. In addition, the MPS can be equipped with a pylon access kit, specifically developed to provide safe and efficient access to pylons, masts, and similar structures. This kit integrates seamlessly with the stair system, offering secure attachment, optimized reach, and enhanced safety for operators working at height. With a modular design, the MPS system can be fully configured to meet specific customer needs and site requirements.

KEY FEATURES:

- Design according to NEN-EN-ISO-14122
- Mounted to basic fixed railing system with steel structural elements
- All gates in colour orange RAL2004
- Locking systems included on gates
- Black non-staining rubber padding
- Slidable side railing with front gates included to enclose FWD Pylon area to safely access tank inspection hatches
- Vertical movable gates include to minimize gap between gate and engine top surface

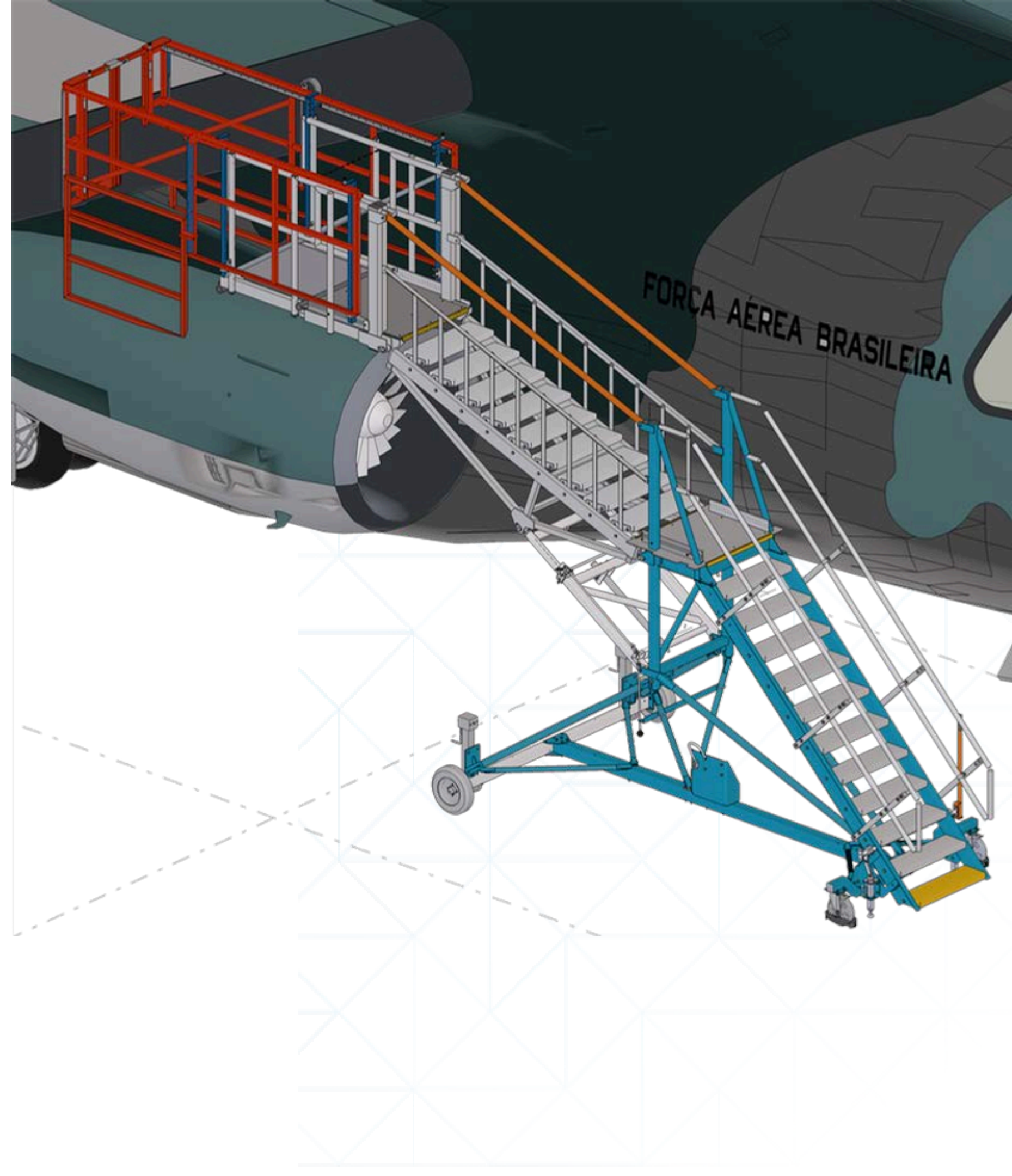

— TAIL & HORIZONTAL STABILISER ACCESS

PN-3012

The platform provides maintenance and overhaul personnel with a safe and ergonomic working area beneath the horizontal stabilizers of the KC-390 aircraft. The system is designed to support stable access for inspection and maintenance tasks while maintaining controlled clearances to aircraft structures. It consists of dedicated left-hand (LH) and right-hand (RH) modules, allowing precise positioning on both sides of the aircraft and ensuring balanced, efficient access to the underside of the horizontal tailplane.

KEY FEATURES:

- Extendable floors and adjustable railing following the aircraft contours for access and fall protection
- Fixed height dock configured for optimal ergonomics and ease of maintenance operation
- Rubber padding for aircraft surface protection
- Side gates for loading and off-loading of aircraft components, tooling and equipment
- Utilities and lighting for aircraft maintenance operations

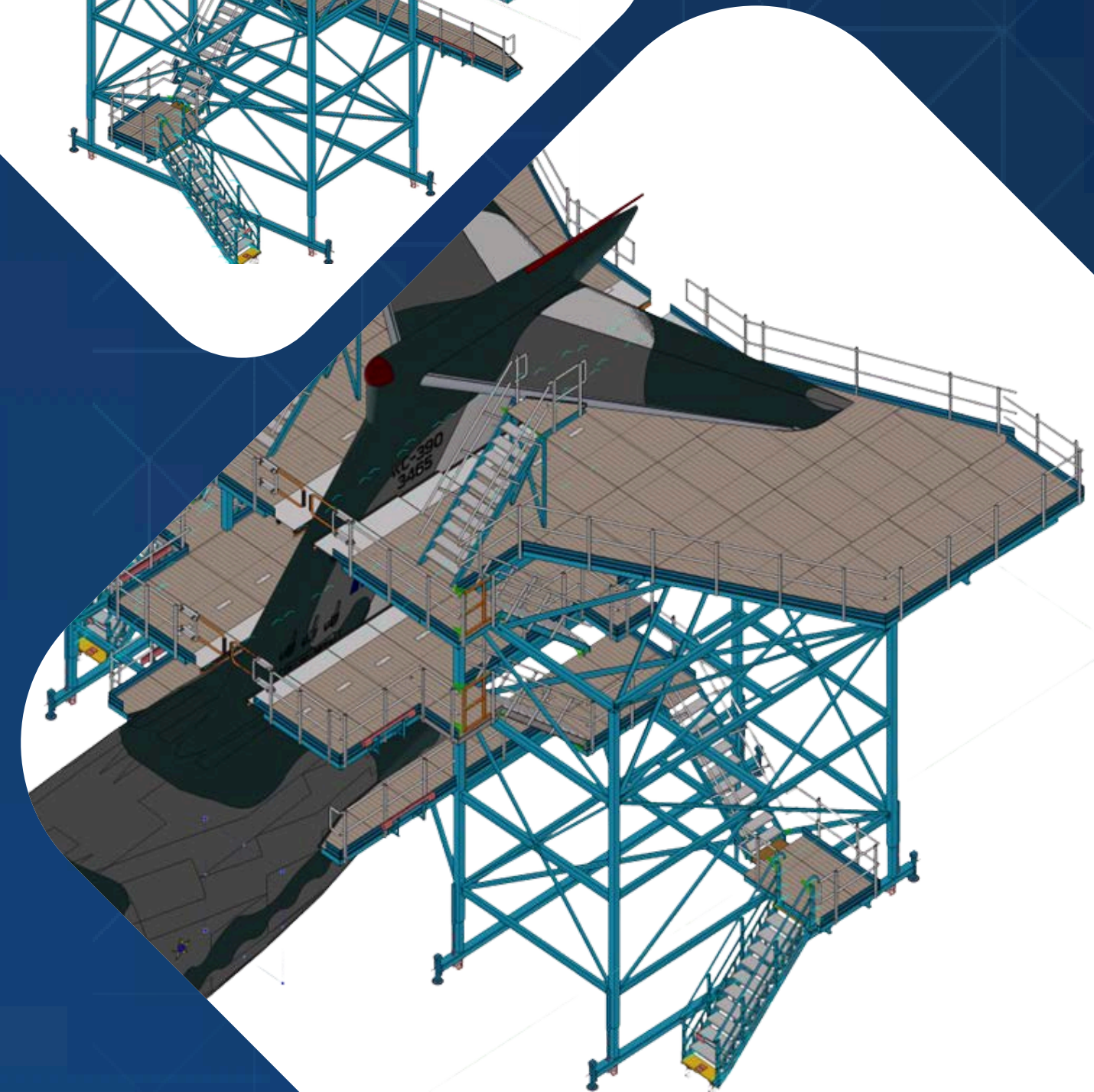

APU ACCESS

PN-3012

This system is specifically designed for use on multiple aircraft types, offering a versatile solution for maintenance tasks. The large working platform provides ample space for APU storage, tools, and maintenance engineers, ensuring everything needed is easily accessible. For safety, the platform is equipped with a self-closing gate to prevent falls, while an electric height adjustment system with remote control allows for precise positioning. In case of an emergency, a safety system is integrated to protect workers. Additionally, a large gate with safety switches facilitates the easy transport of tools or the APU to and from the working platform. With a wide height adjustment range, this system ensures optimal access to various aircraft types.

KEY FEATURES:

- Stable and robust design with reduced footprint
- Built-in stairs to enter the working platform
- Additional steps to access top of APU compartment
- Rubber padding to protect aircraft skin
- Including tow bar



— UNDERWING DOCK

Its ground mobility allows for flexible maintenance operations within the hangar, while the open structural design provides a large storage area beneath the wing dock. It enables full under-wing access for maintenance and flight control surface testing. Constructed from a robust mix of aluminum and steel, the dock meets the latest safety standards for strength and stability.

KEY FEATURES:

- Large sloped floor platform on each aircraft side with walk zones around projected wing area
- Adjustable railing configured for tail-in docking procedures and fall protection
- Rubber padding for aircraft surface protection
- Optional Utilities and lighting for aircraft maintenance operations

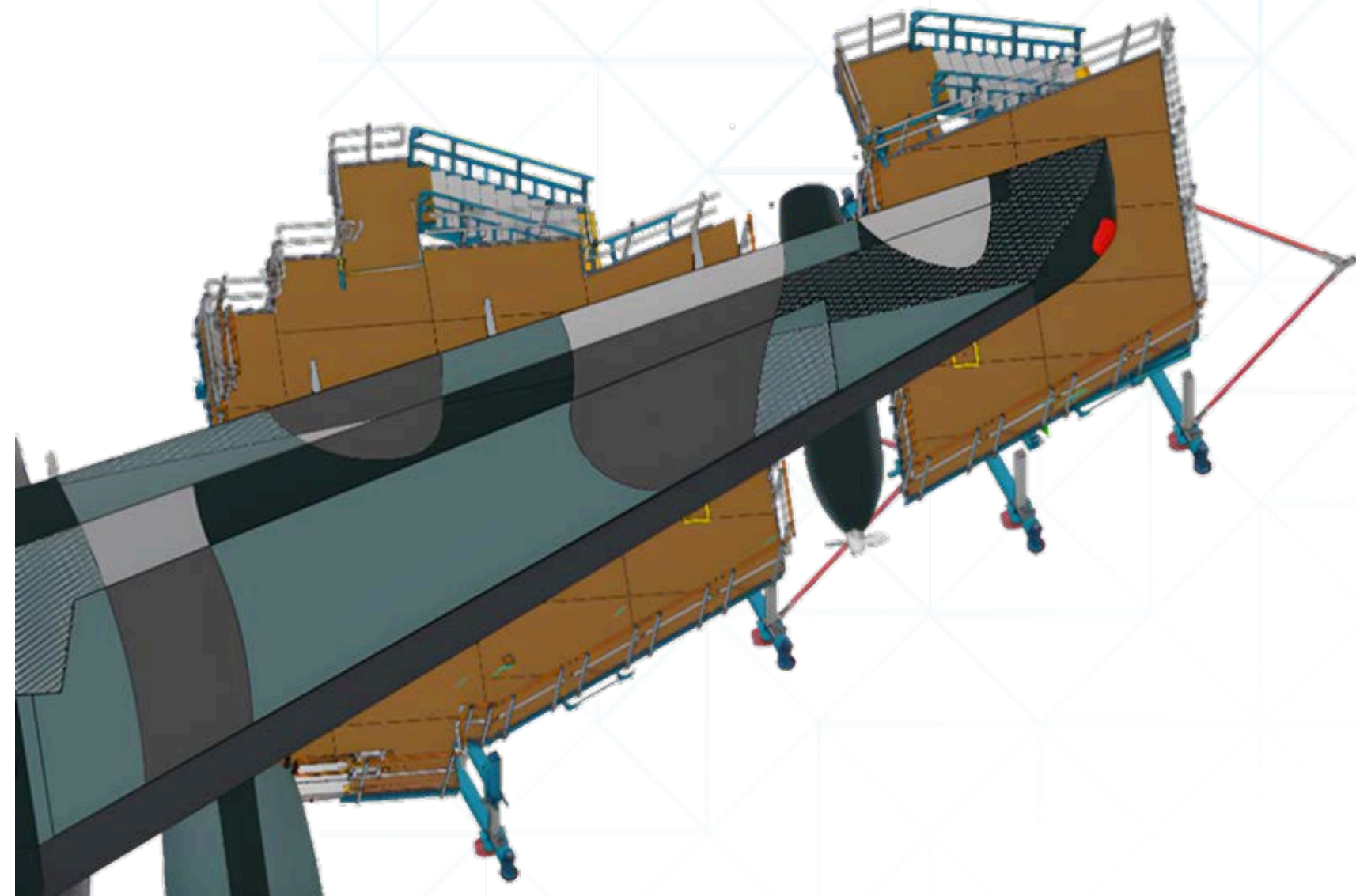
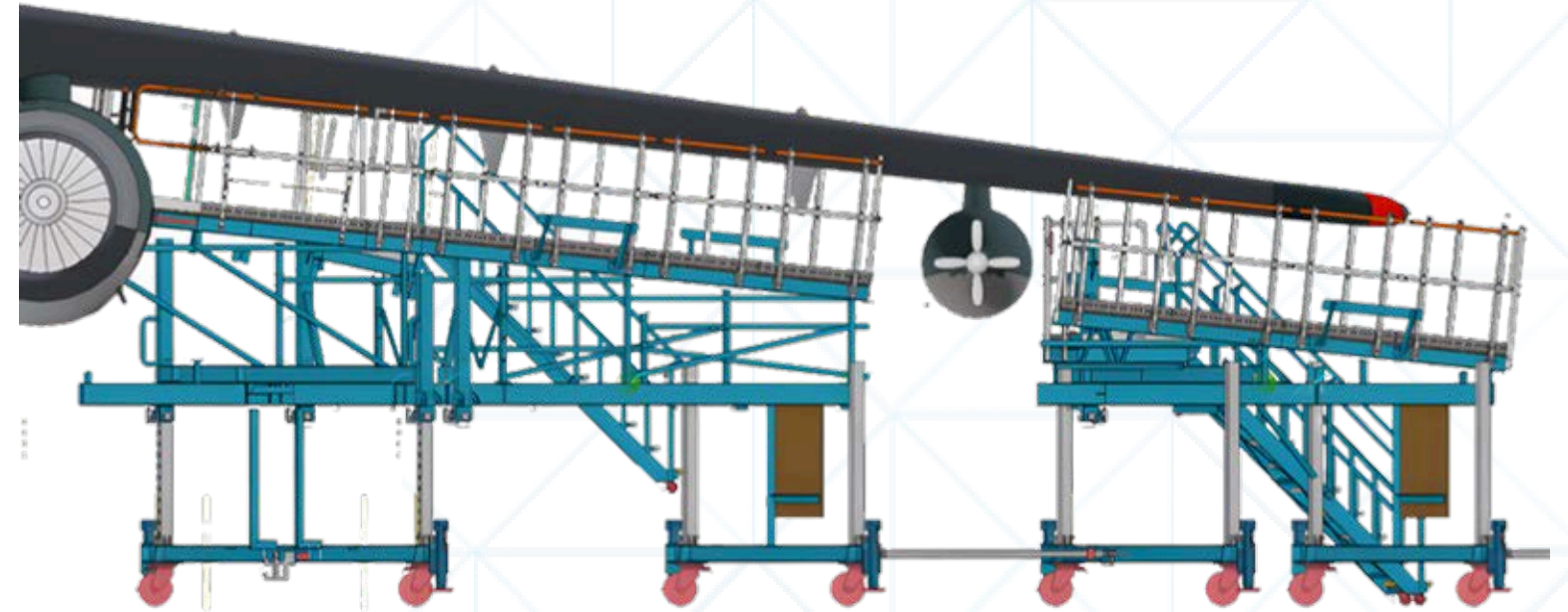



nijl[®]

**For a safe working
environment**

NIJL

Punterweg 4 8042PB

Zwolle

The Netherlands

NCAGE No.: H2BL2

T +31 38 202 80 20

E info@nijlgroup.com

www.nijlgroup.com